



FICHE DE RÉGLAGES

Nom: _____
 Date: _____
 Piste: _____

Conditions de piste:

Taille: Grande Med. Petite
 Accroche: Grosse Med. Faible
 Surface: Défoncée Med. Plate

Différentiels:

Avant: # _____
 Central: # _____
 Arrière: # _____

Moteur:

Type: _____
 Réso: _____ Accord: _____ mm
 Bougie: _____ Carburant: _____

Pneus:

Avant: _____ Arrière: _____
 Gomme: _____ Gomme: _____
 Mousse: _____ Mousse: _____

Embrayage:

Masselottes: _____
 Ressorts: _____ mm
 Rapport: _____

AVANT:

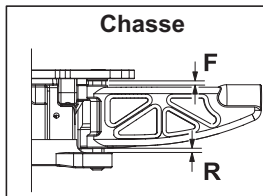
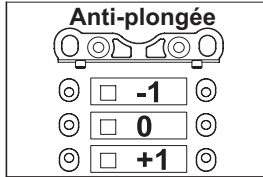
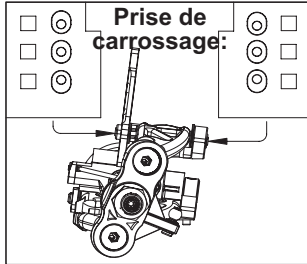
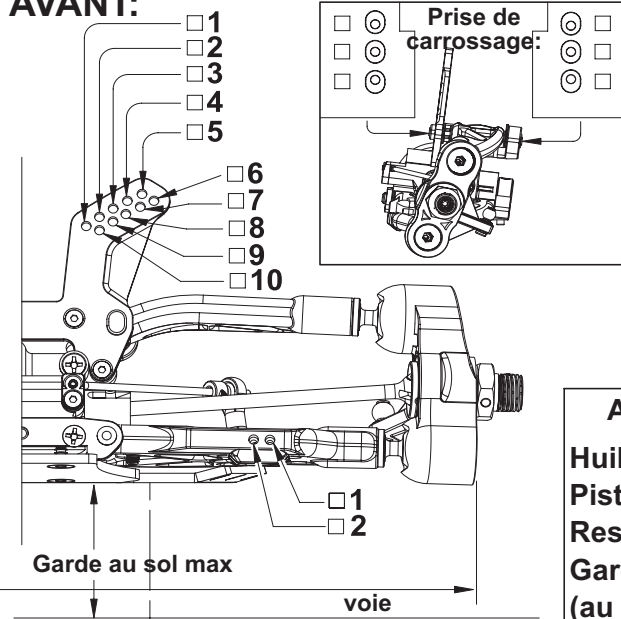

Amortisseurs avt.:
 Huile: _____
 Piston: _____
 Ressort: _____
 Garde au sol: _____ mm
 (au repos)

Voie (largeur): _____ mm
 Carrossage: _____
 (à 20mm de garde au sol)
 Chasse F: _____ mm
 R: _____ mm
 Ouverture: _____
 Garde au sol max: _____ mm
 Barre anti-roulis: oui _____ mm
 non
 ackermann 1 _____ mm
 2 _____ mm
 3 _____ mm
 Notes: _____

ARRIÈRE:

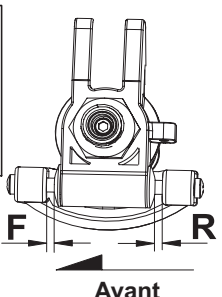
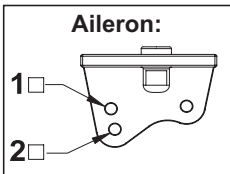
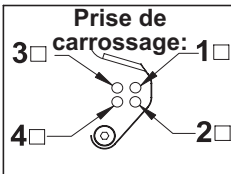
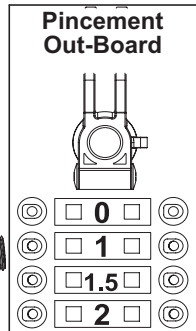
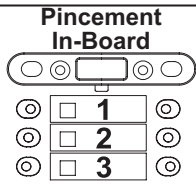
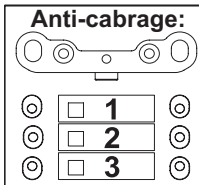
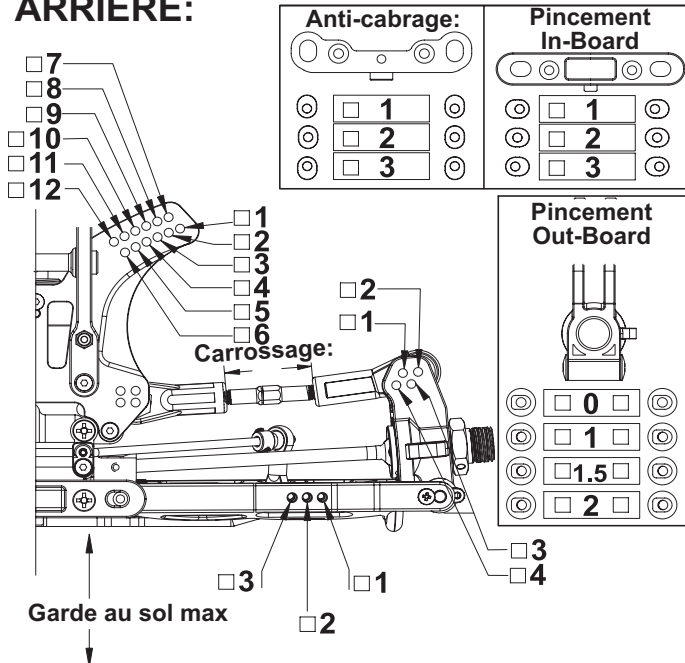

Carrossage: _____ mm
 Garde au sol max: _____ mm
 Empattement F: _____ mm
 R: _____ mm
 Barre anti-roulis: _____ mm

Amortisseurs arr.:
 Huile: _____
 Piston: _____
 Ressort: _____
 Garde au sol: _____ mm
 (au repos)

Notes: _____